

# PNEUMATRON

www.pneumatron.co.za

sales01@pneumatron.co.za

## 2/2 Industrial Solenoid Valve P5W22 Series, Diaphragm Direct Lifting (N.C)

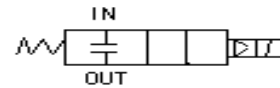

**PLEASE TAKE NOTE OF: Special Notes & Installation Instructions on last page**

- Characteristics:**
1. Semi direct lifting diaphragm construction.
  2. Open from zero bar for low pressure system use.
  3. High frequency of DIN plug coil.

**Medium:** Air, Gas, Water, Light Oil ( $\leq 20$  Centistokes)

**Temperature:** NBR:  $-10^{\circ}\text{C}$  to  $80^{\circ}\text{C}$

**Pressure:** 0 to 6 Bar (see table below)

**Body:** Nylon (PA66)

**Port Size (BSP):** 1/2", 3/4", 1", 1 1/2", 2"

**Orifice:** 15mm, 20mm, 25mm, 40mm, 50mm

**Coil voltages:** 220VAC, 24VAC, 24VDC, 12VDC

**Coils:** IP65, 100%ED

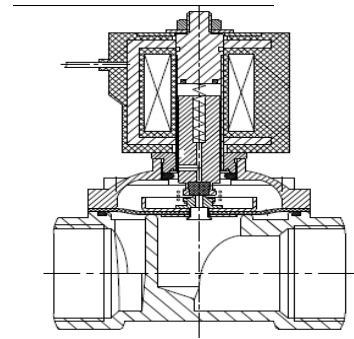

**Material:**

Body: Nylon (PA66)

Seal: NBR (Buna)

Armature Tube: Stainless Steel 304

Plunger: Stainless Steel 430F

Springs: SS304

Shading Rings: Copper

### P5W22 Series, Normally Closed, with Coil

Port size	Orifice (mm)	KV	Min Pressure	Max Pressure			Seals Material	Body Material	Valve Body	Coil
				220VAC (33VA)	24VAC (33VA)	12/24VDC (20W)				
1/2"	15	4.15	0 Bar	7 Bar	7 Bar	6 Bar	NBR (Buna)	Nylon (PA66)	P5W22NH15S04B	C14/15
3/4"	20	6.57	0 Bar	7 Bar	7 Bar	6 Bar			P5W22NH20S06B	C14/15
1"	25	10.38	0 Bar	7 Bar	7 Bar	6 Bar			P5W22NH25S10B	C14/15
				220VAC (55VA)	24VAC (55VA)	12/24VDC (40W)				
1 1/2"	40	25.95	0 Bar	6 Bar	3 Bar	5 Bar			P5W22NH40S14B	C41
2"	50	41.52	0 Bar	6 Bar	1.5 Bar	5 Bar			P5W22NH50S20B	C41

# PNEUMATRON

[www.pneumatron.co.za](http://www.pneumatron.co.za)

[sales01@pneumatron.co.za](mailto:sales01@pneumatron.co.za)

## 2/2 Industrial Solenoid Valve P5W22 Series, Diaphragm Direct Lifting (N.C)

BODY DIMENSION CODE(Size in mm)				Valve Body
A	B	C	Port size	
76	68	107	1/2" (15)	P5W22NH15S04B
80	68	111	3/4" (20)	P5W22NH20S06B
107	82	117	1" (25)	P5W22NH25S10B
140	112	170	1 1/2" (40)	P5W22NH40S14B
159	130	190	2" (50)	P5W22NH50S20B

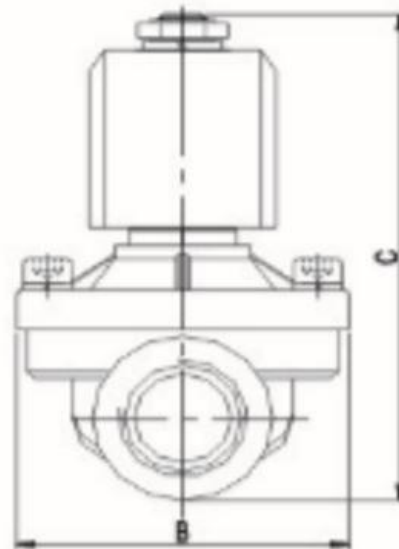
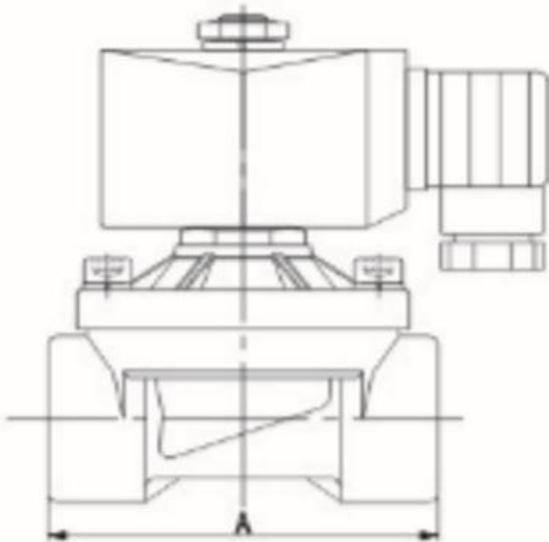

# PNEUMATRON

[www.pneumatron.co.za](http://www.pneumatron.co.za)

[sales01@pneumatron.co.za](mailto:sales01@pneumatron.co.za)

## SPECIAL NOTES FOR P5W22 NYLON VALVE SERIES

**a.** These valve do operate from zero pressure due to a large electrical coil that is fitted onto the valve (See wattage of coils in table on first page). These large coils are capable of pulling the diaphragm up once energised without any assistance or pressure. Due to this the valves are suitable to be used on gravity feed applications as well as on the suction side of a pump.

**b.** These large coils need to be protected against overheating by the following methods:

**1.** No installation in direct sunlight. If the solenoid valve is installed in direct sunlight the coil and valve must be shaded - a shading steel plate can be mounted above the valve to protect it from direct sunlight. DO NOT box these valve to block direct sunlight, there will be no ventilation to keep the coil cool unless you mount a fan.

**2.** Frequent switching more than once in 10 minutes, not allowed. Duty cycle has to be on for max 20% and off for 80% of the time. Coil cannot be activated for extended periods of time without sufficient flow of cool water to help keeping the coil cool, because plastic does not conduct the heat from the coil so the valve body cannot assist with coil cooling like with metal valves. Please consult the flow rate specifications for these flow rates (your pump specified flow rate has to exceed the valve flow rate by 50%, if the pump is small and the valve is large you can expect the coil to overheat and eventually burn out).

**3.** An alternative solution would be to use our PX Brass Ball Valve series which is only 1", but it has no restrictions and no pressure drops unlike these plastic diaphragm valves.

**4.** Please make sure of required wattage for C41 & C14 coils before purchase.

## VALVE INSTALLATION INSTRUCTIONS

**1.** These valves should be installed horizontally with the coil on top for the best and most reliable operation, any other installation method is done at own risk.

**2.** Insure that the valve is installed correctly as per the flow direction indicated by and arrow on the valve, in/out wording or as per instruction in the data sheet. Incorrect installation will result in malfunction of the valve and possible damage.

**3.** Check the valve label for pressure range requirements. Any valve should not be used for higher pressure than what they are rated for.

**4.** The valve label will indicate the valve body material and the seal material. Never apply incompatible fluids or gasses with the body and seal material.

**5.** The seal material indicates the temperature range that can be used with the valve. Going beyond the temperature range will cause the valve to malfunction.

**6.** All valves should be cleaned from time to time. Generally, if the voltage to the coil is correct, sluggish valve operation, excessive noise or leakage will indicate that cleaning is required.